

Technical Specifications

Cooling Distribution Unit (CDU)

Chilled Water

Up to 12 InRow RC units (100 series)



American Power Conversion Legal Disclaimer

The information presented in this manual is not warranted by the American Power Conversion Corporation to be authoritative, error free, or complete. This publication is not meant to be a substitute for a detailed operational and site specific development plan. Therefore, American Power Conversion Corporation assumes no liability for damages, violations of codes, improper installation, system failures, or any other problems that could arise based on the use of this Publication.

The information contained in this Publication is provided as is and has been prepared solely for the purpose of evaluating data center design and construction. This Publication has been compiled in good faith by American Power Conversion Corporation. However, no representation is made or warranty given, either express or implied, as to the completeness or accuracy of the information this Publication contains.

IN NO EVENT SHALL AMERICAN POWER CONVERSION CORPORATION, OR ANY PARENT, AFFILIATE OR SUBSIDIARY COMPANY OF AMERICAN POWER CONVERSION CORPORATION OR THEIR RESPECTIVE OFFICERS, DIRECTORS, OR EMPLOYEES BE LIABLE FOR ANY DIRECT, INDIRECT, CONSEQUENTIAL, PUNITIVE, SPECIAL, OR INCIDENTAL DAMAGES (INCLUDING, WITHOUT LIMITATION, DAMAGES FOR LOSS OF BUSINESS, CONTRACT, REVENUE, DATA, INFORMATION, OR BUSINESS INTERRUPTION) RESULTING FROM, ARISING OUT, OR IN CONNECTION WITH THE USE OF, OR INABILITY TO USE THIS PUBLICATION OR THE CONTENT, EVEN IF AMERICAN POWER CONVERSION CORPORATION HAS BEEN EXPRESSLY ADVISED OF THE POSSIBILITY OF SUCH DAMAGES. AMERICAN POWER CONVERSION CORPORATION RESERVES THE RIGHT TO MAKE CHANGES OR UPDATES WITH RESPECT TO OR IN THE CONTENT OF THE PUBLICATION OR THE FORMAT THEREOF AT ANY TIME WITHOUT NOTICE.

Copyright, intellectual, and all other proprietary rights in the content (including but not limited to software, audio, video, text, and photographs) rests with American Power Conversion Corporation or its licensors. All rights in the content not expressly granted herein are reserved. No rights of any kind are licensed or assigned or shall otherwise pass to persons accessing this information.

This Publication shall not be for resale in whole or in part.

Table of Contents

- Technical Data..... 1**
 - Model Identification.....1**
 - Model identification label location 1
 - Model nomenclature 1
 - Features and Options2**
 - Capacity 2
 - Cooling Distribution 2
 - Configuration 2
 - Compliance Approval 2
 - Standard Components 3
 - Scalable Solution for Critical Environments.....4**
 - Overhead Piping Design 4
 - High Density 4
 - Coolant Balancing 4
 - Leased Facilities 4
 - APC by Schneider Electric Cooling Distribution Unit: The Right Solution 4
 - Chilled Water Configuration 5
 - Cooling Distribution Unit Advantages 5
 - InRow Advantages 6
 - Standard Features7**
 - Single Skin Panels 7
 - Isolation and Balancing Valves 7
 - Main Supply and Return Headers 7
 - Multiple Distribution Supply and Return Lines 7
 - Top or Bottom Distribution Piping Connections 7
 - Pipe Fittings 7
 - Clamps/Hangers 7
 - Jointless Piping 8
 - Flexible Piping 8
 - Pipe Insulation 8
 - Component Identification9**
 - External components 9
 - Interior – piping configuration 10
 - Performance Data11**
 - CDU Pressure Drop 12
 - Piping Data 12
 - Calculating Pressure Drop 13
 - Dimensional Data.....14**
 - CDU Assembled Module 14
 - Piping Connection 15

Warranty 17
Guide Specifications 19
 Guide Specifications for the CDU19

Technical Data

Model Identification

Model identification label location

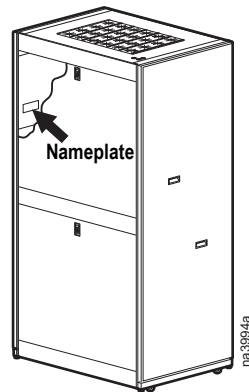

Model nomenclature

Model Selection

ACFD12-T

ACFD12-B

Naming Convention

AC

FD

12

Piping Arrangement

Description

Cooling solution product line

Cooling Distribution Product Family

Number of circuits

T = Top

B = Bottom

Features and Options

The scalable, cooling distribution unit offers efficient, effective, and economical fluid distribution for use with the InRow RC 100 series.

Precision environmental requirements now reach far beyond the confines of the traditional data center or computer room to encompass a larger suite of applications referred to as technology rooms. Critical environment applications include:

- Computer rooms
- Telecommunication facilities
- Clean rooms
- Power Equipment
- Medical equipment rooms
- Archives
- LAN/WAN environments

A worldwide network of APC by Schneider Electric representatives is fully qualified to provide engineering, sales, installation, and service for our products.

APC by Schneider Electric warrants all parts for 12 months from shipment. Extended warranties are available.

Capacity

The Cooling Distribution Unit or CDU is available for up to 12 InRow RC 100 series units.

Cooling Distribution

Cooling distribution systems are placed either inside or outside of the data center. Fluid is pumped into the CDU main supply header from the chiller, distributed into individual supply lines, absorbs rejected heat from the air through the CW, and is routed back to the chiller through the CDU return lines.

The CDU is manually set to ensure that fluid flow is equal to all of the InRow RC Air Conditioners. Improper fluid flow could result in hot spots within the data center.

Configuration

- Chilled Water
- Glycol/Chilled Water

Compliance Approval

- UL Listed to UL 1995 and CSA C22.2 No. 236



Standard Components

- Manual Isolation and Balancing Valve
- Individually controlled supply and return lines
- Multiple Supply and Return Lines
- Main Supply and Return Headers
- Distribution Piping as Top or Bottom Configuration
- Flexible and Jointless Piping
- Pipe Couplings
- Pipe Insulation
- Pipe Clamp / Hanger
- Secure Lockable Panels
- Main Supply and Return (Field Configurable as Top or Bottom)
- Matching Brass and Dielectric Flanges for Chilled Water Connection

Scalable Solution for Critical Environments

Overhead Piping Design

Mitigating the risk of fluid leaks is critical to the smooth operation of a technology room. However, raised floors are not an option in some data center environments. This hard floor environment requires that the cooling fluid piping be installed overhead. Because traditional hard copper piping has numerous joints, the risk of leaks increases in the data center. The use of flexible piping allows the system to be routed overhead without the use of elbows or any intermediate joints from the chilled water source to each InRow RC, greatly reducing the leak and condensation potential in the pipe system. This solution reduces the concern of users and IT managers by routing chilled water piping away from their IT equipment.

High Density

In a technology room, the consolidation of servers, whether from constraints on space or from moving data on multiple clusters of servers to a single, larger server, cause high density areas.

Naturally, this will make the power densities increase, resulting in a higher than average cooling load per rack. The higher cooling demand might require additional Computer Room Air Conditioner (CRAC) units, and thus require additional fluid lines to be installed. Traditional approaches employ hard copper piping which requires an increase in labor and deployment time when infrastructure demands change.

Coolant Balancing

High density environments demand multiple CRAC units to handle the cooling load required by the IT equipment. To handle this load, multiple fluid lines need to be routed through the data center to the CRACs. Each of the fluid lines employs individual valves that are located in areas that may not be accessible from the data center.

Leased Facilities

Installing a data center in a leased facility is usually not a significant issue since the IT equipment can be removed from the racks. However, the actual valves and piping are typically not moved.

The Network Critical Physical Infrastructure (NCPI) must be portable so that it is easily moved to a new location.

A raised floor is not typical in leased facilities. Deploying a NCPI without the use of a raised floor eliminates a one-time expenditure.

APC by Schneider Electric Cooling Distribution Unit: The Right Solution

Highly scalable and flexible, the system is capable of growing with your cooling needs as they increase. Each unit comes with isolation/balancing valves for fluid control of each circuit.

Chilled Water Configuration

Chilled water systems utilize water from an APC by Schneider Electric air cooled modular chiller or a customer supplied chiller for cooling. Chilled water is commonly used in large buildings and can serve multiple indoor units.

- System used with an air cooled modular chiller
- Cost effective for large installations

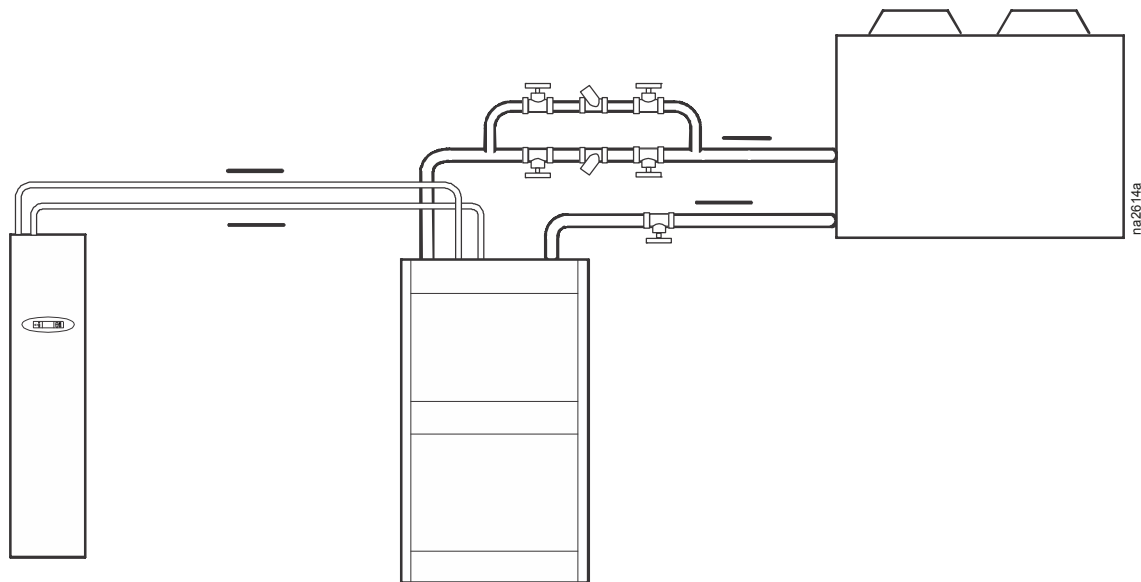

Cooling Distribution Unit Advantages

The Cooling Distribution Unit is capable of adapting easily to increasing cooling loads. The flexible piping reduces the risks of leaks within the data center and has multiple supply and return lines, which allow scalability for medium and large data centers (including high density applications). The CDU also uses a simple centralized fluid distribution strategy, which is easily deployed without adding to the design and installation expenses. The flexible piping provides a joint-less piping run to the InRow RC.

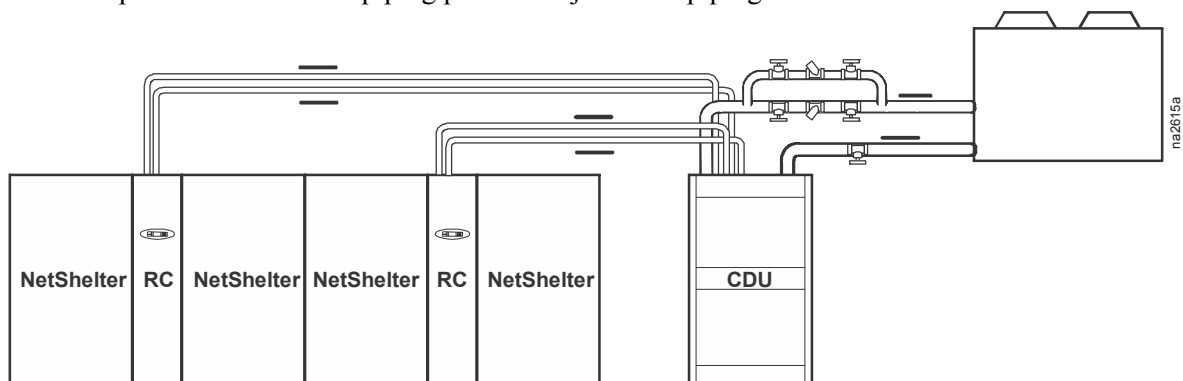

The CDU also provides the flexibility to pipe the main supply and return connections from the chiller from the top (overhead) or the bottom (from a raised floor), regardless of the distribution piping configuration. The CDU will ship with two brass counter flanges for connection of copper mains and two dielectric flanges for connection to steel piping.

InRow Advantages

The InRow solution improves energy efficiency and cooling ability in a number of ways. First, the CW draws air directly from the hot aisle, allowing the CW to take advantage of higher heat transfer efficiency due to higher temperature differences. It can then discharge room temperature air directly in front of the servers it is cooling. This increases energy efficiency by allowing the chiller to operate at higher leaving water temperatures. Also, since the InRow RC never chills the air below its dewpoint, very little if any dehumidification occurs, significantly decreasing water consumption and energy use, and eliminating heat transfer inefficiencies caused by wet coils.

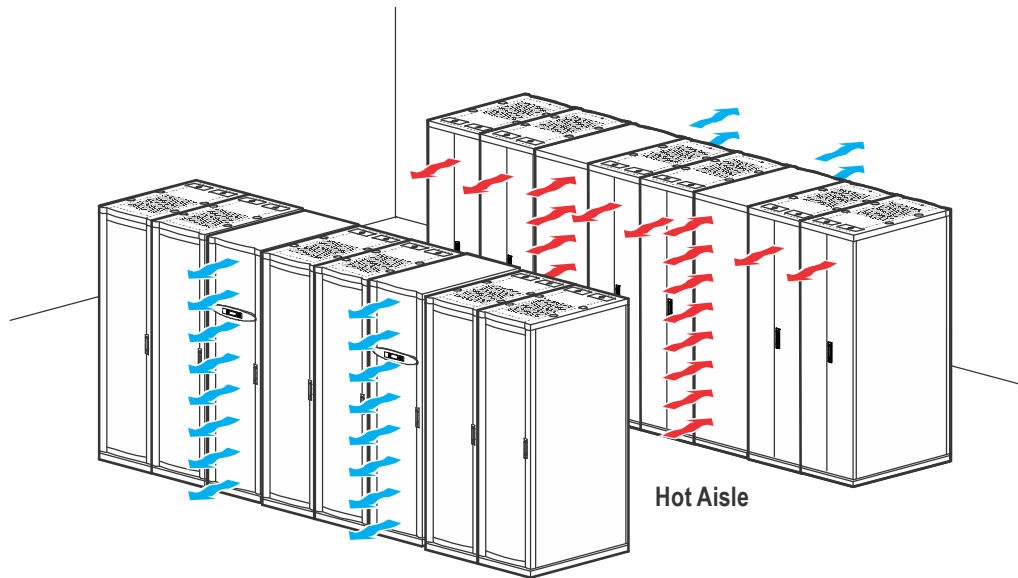

Standard Features



Single Skin Panels

The frame is formed 16 gauge steel bolted together for maximum strength. The cabinet is serviceable from the front and both sides. All exterior panels and corner posts on the frame are powder coated for durability and an attractive finish. Front and back exterior panels are 18 gauge steel and the side exterior panels are 20 gauge steel. The front top and bottom panels are removable for easy access for service and installation.

Isolation and Balancing Valves

Each unit includes balancing / isolation valves on each circuit and isolation valves on the return for servicing. The valves provide coolant flow adjustment in one centralized location

Main Supply and Return Headers

Main supply and return headers supply coolant to the individual supply lines and return coolant to the Air Cooled Modular Chiller.

Multiple Distribution Supply and Return Lines

Up to 12 InRow RC units can be connected to allow scalability, which is required for medium to large data centers. These individual supply and return lines supply coolant to the individual CW units and return coolant to the main header.

Top or Bottom Distribution Piping Connections

Top or bottom connections provide the customer with the option of piping the unit from the top or the bottom, depending on the layout of their data center.

Pipe Fittings

Pipe fittings and couplings, specifically designed for use with PEX-AL-PEX piping, provide a reliable and leak resistant connection between the flexible piping, the CDU, and the CW units.

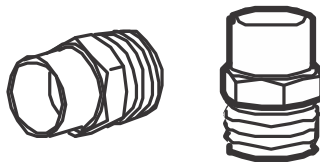

Clamps/Hangers

Clamps secure the piping and permit the use of threaded rods for anchoring. The clamps also provide a clean and organized method for installing piping within the data center.

Jointless Piping

A jointless installation between the CDU and the InRow RC minimizes the potential for leaks, which enables the piping to be installed overhead above the aisles when a raised floor is not available.

Flexible Piping

Flexible piping allows one-time engineering and portability, since the deployment of the piping can be easily modified as the infrastructure demands change.

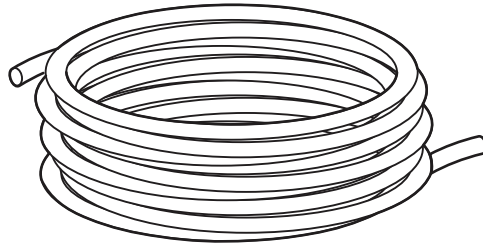

Pipe Insulation

The Cooling Distribution Unit's piping is insulated to prevent condensation. Insulation is also provided for field installation on the piping between the CDU and the InRow RC.

Component Identification

External components

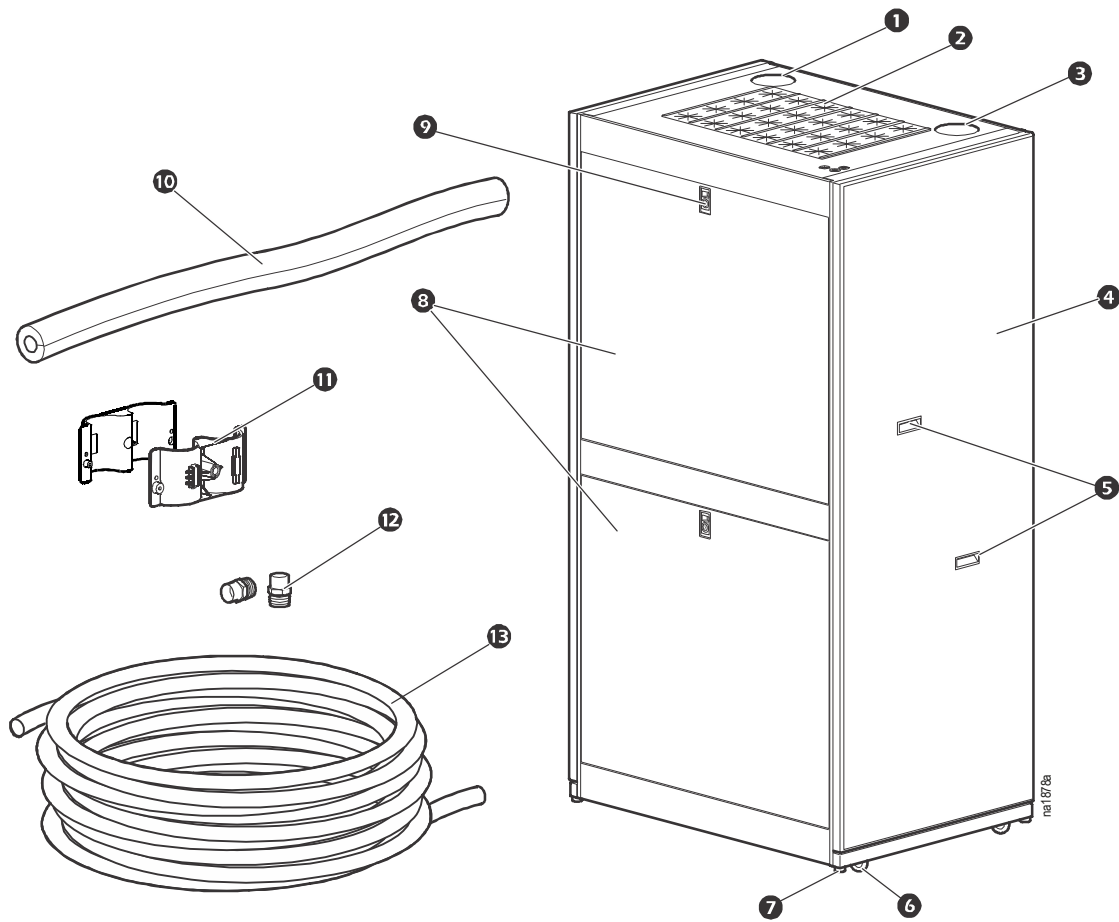

- ❶ Chiller return (top piping)
- ❷ Pipe pass-through (top piping)
- ❸ Chiller supply (top piping)
- ❹ Side panel
- ❺ Lift handle
- ❻ Casters
- ❼ Leveling foot
- ❽ Front panels
- ❾ Front panel lock
- ❿ 35.05 mm (1.38 in) x 12.7 mm (1/2 in) closed cell insulation
- ⓫ Pipe clamps
- ⓬ Pipe fittings
- ⓭ PEX-AL-PEX flexible piping

Interior – piping configuration

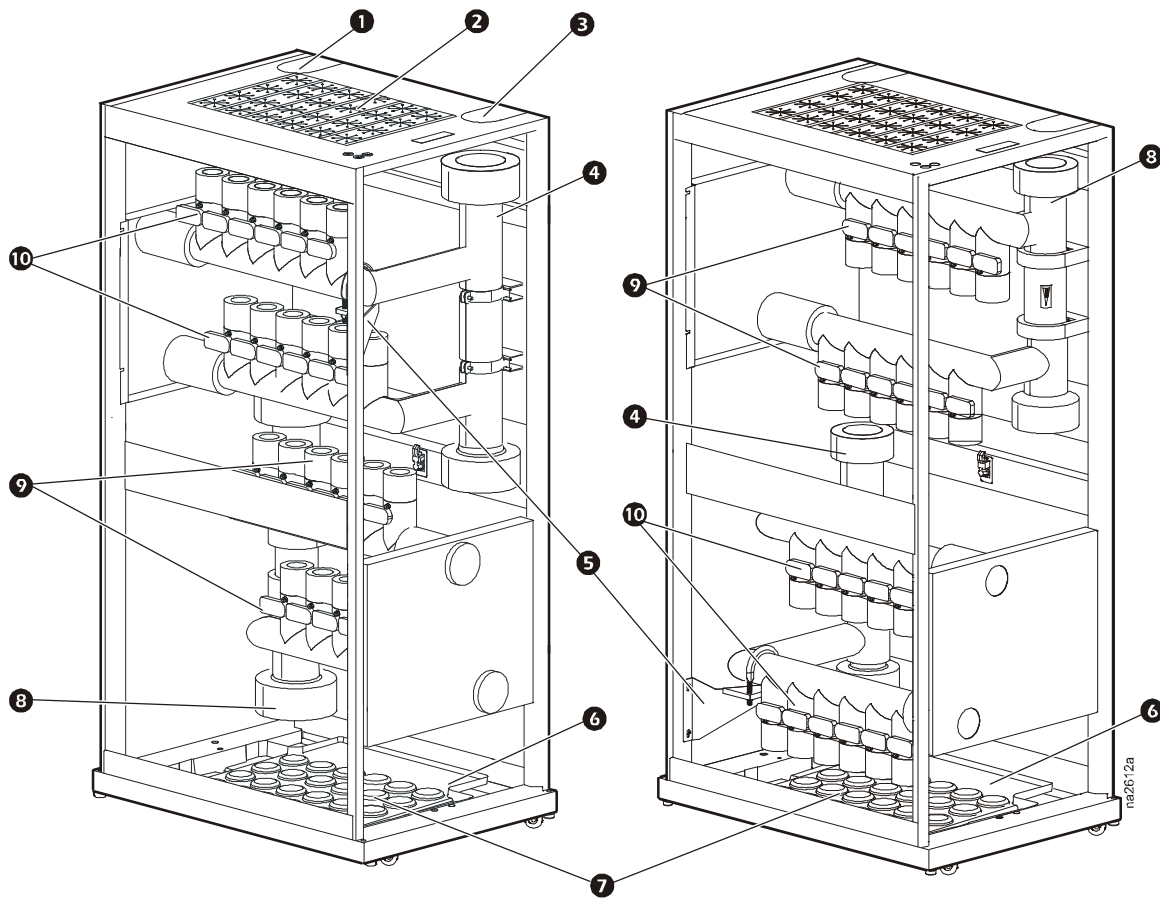

Panels removed for clarity

- | | |
|---------------------------------------|--|
| ❶ Top access to chiller return header | ❸ Top access to chiller supply header |
| ❷ Top flexible pipe pass-through | ❹ Chiller supply header |
| ❺ Shipping bracket | ❻ Condensate drain pan |
| | ❼ Bottom flexible piping pass-through with plugs |
| | ❽ Chiller return header |
| | ❾ 1-in full port ball valve (return) |
| | ❿ 1-in calibrated balancing valve (supply) |

Performance Data

PHYSICAL DATA		
Weight – kg (lbs)		
	Net Weight	240 (530)
	Operating Weight	254 (560)
	Shipping Weight	287 (632)
Nominal Dimensions – mm (in)*		
	Net Height	1991 (78.4)
	Shipping Height	2159 (85)
	Net Width	1070 (42.13)
	Shipping Width	1219 (47.99)
	Net Depth	750 (29.53)
	Shipping Depth	889 (35)
CONNECTION SIZES – mm (in) nominal		
	Supply to InRow RC – FTP	25.4 (1)
	Return from InRow RC – FTP	25.4 (1)
	Main Supply from Chiller** – Flange	76.2 (3)
	Main Return from Chiller** – Flange	76.2 (3)
CONTROL VALVES – mm (in) nominal		
	Isolation Ball Valve	25.4 (1)
	Balancing Ball Valve	25.4 (1)
FLOW RATE		
	Max Flow Rate of CDU – l/s (GPM)	11.4 (175)
WORKING PRESSURE		
	Maximum Working Pressure of CDU – kPa (psi)	1035 (150)
SCALABILITY		
	MAX # of InRow RC units supported	12
	MIN # of InRow RC units supported	1
	MAX length of PEX Piping between the CDU and InRow RC unit – m (ft)	45.72 (150)

*See drawings on following pages for actual dimensions

**Connection sizes, not recommended piping sizes

CDU Pressure Drop

CDU PRESSURE DROP		
Number of InRow RC units supported	Flow Rate through PEX-AL-PEX Piping	Total Pressure Drop
Quantity	l/s (GPM)	kPa (ft of H ₂ O)
1–12	0.13 (2)	0.6 (0.2)
1–12	0.25 (4)	2.7 (0.9)
1–12	0.38 (6)	6.0 (2)
1–12	0.50 (8)	10.2 (3.4)
1–12	0.63 (10)	15.9 (5.3)
1–12	0.76 (12)	22.7 (7.6)
1–12	0.88 (14)	30.5 (10.2)
1–10	1.00 (16)	39.8 (13.3)
1–9	1.14 (18)	49.9 (16.7)
1–9	1.17 (18.5)	52.6 (17.6)

Piping Data

PEX-AL-PEX PRESSURE DROP		PIPE BEND LENGTH FOR PRESSURE DROP	
Flow Rate through PEX-AL-PEX piping	Pressure Drop through piping / ft of PEX-AL-PEX	Estimated Number of Bends in PEX-AL-PEX	Equivalent Pipe Length
GPM (l/s)	kPa/m (ft H ₂ O/ft of pipe)	Quantity	m (ft)
0.13 (2)	0.04 (0.004)	1	.31 (1)
0.25 (4)	0.1 (0.01)	2	.61 (2)
0.38(6)	0.29 (0.03)	3	.92 (3)
0.50 (8)	0.49 (0.05)	4	1.22 (4)
0.63(10)	0.69 (0.07)	5	1.53 (5)
0.76 (12)	0.98 (0.1)	6	1.83 (6)
0.88 (14)	1.28 (0.13)	7	2.14 (7)
1.00 (16)	1.67 (0.17)	8	2.44 (8)
1.14 (18)	2.06 (0.21)	9	2.75 (9)
1.17 (18.5)	2.06 (0.21)	10	3.05 (10)

*For Pressure Drop Calculation only. Do not include equivalent pipe length in total PEX-AL-PEX length for installation.

Calculating Pressure Drop

Pressure drop of the system should be based on the highest individual circuit, which is dependent on line length and flow rate.

Example: Pressure Drop Calculation:

Given Data:

- GPM = 12
- Linear Distance between CDU and CW = 80 ft
- Estimated Number of Bends in Piping from CDU to CW = 10 (5 Supply, 5 Return)

1. Determine total PEX-AL-PEX length for pressure drop calculation

$$\text{PEX-AL-PEX length} = 80 \text{ ft (supply)} + 80 \text{ ft (return)} = 160 \text{ ft}$$

$$\text{Equivalent PEX-AL-PEX length for bends} = 10 \text{ ft (10 bends} = 10 \text{ ft)}$$

(from Pipe Bend Length table)

$$\text{Total PEX-AL-PEX length for pressure drop calculation} = 160 \text{ ft} + 10 \text{ ft} = 170 \text{ ft}$$

2. Determine pressure drop of PEX-AL-PEX piping (including bends)

$$\text{Pressure drop of PEX-AL-PEX} = 0.1 \text{ ft of water/ft of PEX-AL-PEX at 12 GPM}$$

(from PEX-AL-PEX Pressure Drop table)

$$\text{Total pressure drop of PEX-AL-PEX for 170 ft} = 0.1 \text{ ft of water/ft of PEX-AL-PEX} * 170 \text{ ft} = 17 \text{ ft of water}$$

3. Determine pressure drop of CDU

$$\text{Pressure drop of CDU} = 7.6 \text{ ft of water at 12 GPM (from CDU Pressure Drop table)}$$

4. Determine total pressure drop of PEX-AL-PEX and CDU

$$\text{Total pressure drop of PEX-AL-PEX and CDU} = 17 \text{ ft of water} + 7.6 \text{ ft of water} = 24.6 \text{ ft of water}$$

Dimensional Data

CDU Assembled Module

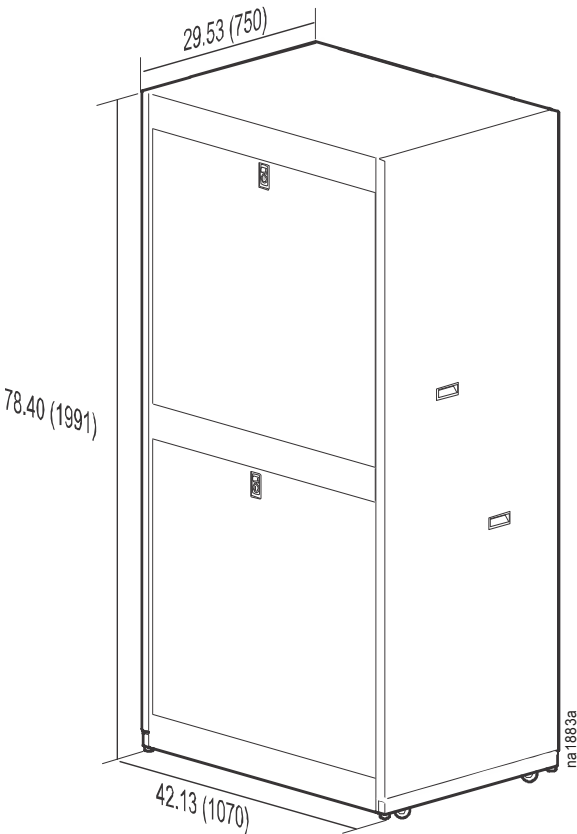

Note: All dimensions are in inches (millimeters).
Note: Minimum clearance for overhead piping is 18 inches (457.2 millimeters) from top of CDU.
Note: Minimum raised floor height for bottom piping is 12 inches (304.8 millimeters).

Piping Connection

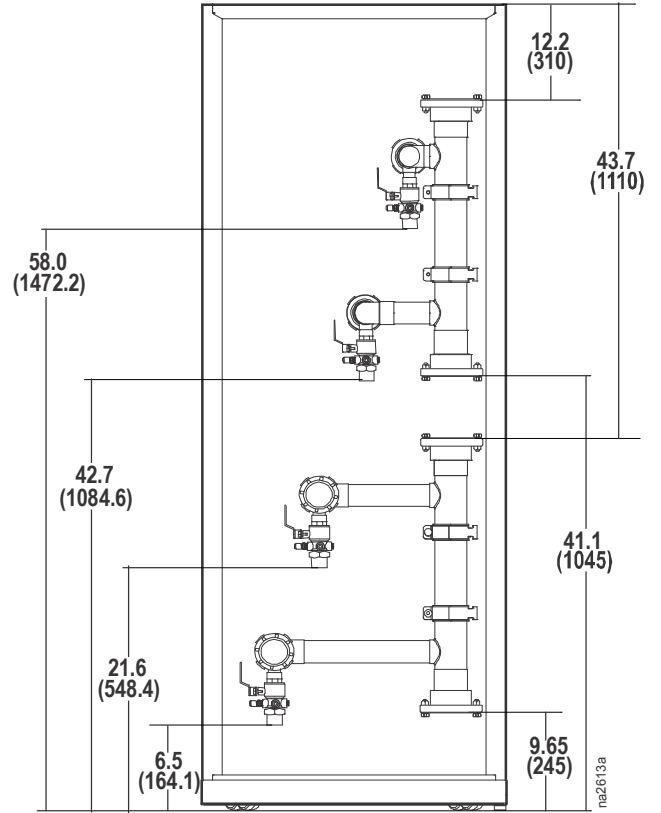
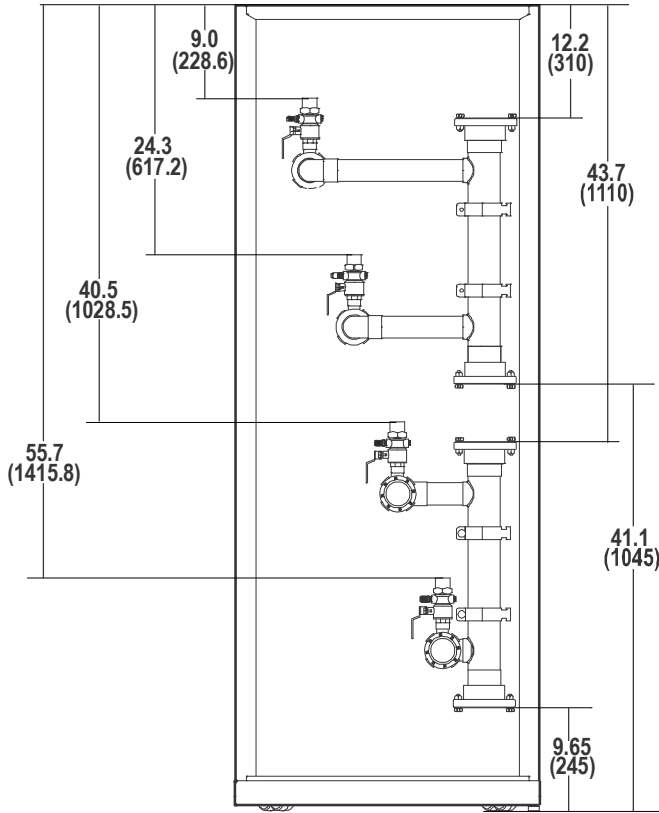

Note: All dimensions are inches (millimeters)

Warranty

Three-Phase Power Products or Cooling Solutions One-Year Factory Warranty

The limited warranty provided by American Power Conversion (APC™) in this Statement of Limited Factory Warranty applies only to products you purchase for your commercial or industrial use in the ordinary course of your business.

Terms of warranty

APC warrants that the product shall be free from defects in materials and workmanship for a period of one year from the date of product start-up when start-up is performed by APC authorized service personnel and occurs within six months of the APC shipment date. This warranty covers repairing or replacing any defective parts including on-site labor and travel. In the event that the product fails to meet the foregoing warranty criteria, the warranty covers repairing or replacing defective parts at the sole discretion of APC for a period of one year from the shipment date. For APC cooling solutions, this warranty does not cover circuit breaker resetting, loss of refrigerant, consumables, or preventive maintenance items. Repair or replacement of a defective product or part thereof does not extend the original warranty period. Any parts furnished under this warranty may be new or factory-remanufactured.

Non-transferable warranty

This warranty is extended to the first person, firm, association or corporation (herein referred to by “You” or “Your”) for whom the APC product specified herein has been purchased. This warranty is not transferable or assignable without the prior written permission of APC.

Assignment of warranties

APC will assign you any warranties which are made by manufacturers and suppliers of components of the APC product and which are assignable. Any such warranties are assigned “AS IS” and APC makes no representation as to the effectiveness or extent of such warranties, assumes no responsibility for any matters which may be warranted by such manufacturers or suppliers and extends no coverage under this Warranty to such components.

Drawings and descriptions

APC warrants for the warranty period and on the terms of the warranty set forth herein that the APC product will substantially conform to the descriptions contained in the APC Official Published Specifications or any of the drawings certified and agreed to by contract with APC if applicable thereto (“Specifications”). It is understood that the specifications are not warranties of performance and not warranties of fitness for a particular purpose.

Exclusions

APC shall not be liable under the warranty if its testing and examination disclose that the alleged defect in the product does not exist or was caused by end user or any third person’s misuse, negligence, improper installation or testing. Further, APC shall not be liable under the warranty for unauthorized attempts to repair or modify wrong or inadequate electrical voltage or connection, inappropriate on-site operation conditions, corrosive atmosphere, repair, installation, start-up by non-APC designated personnel, a change in location or operating use, exposure to the elements, Acts of God, fire, theft, or installation contrary to APC recommendations or specifications or in any event if the APC serial number has been altered, defaced, or removed, or any other cause beyond the range of the intended use.

THERE ARE NO WARRANTIES, EXPRESS OR IMPLIED, BY OPERATION OF LAW OR OTHERWISE, OF PRODUCTS SOLD, SERVICED OR FURNISHED UNDER THIS AGREEMENT OR IN CONNECTION HEREWITH. APC DISCLAIMS ALL IMPLIED WARRANTIES OF MERCHANTABILITY, SATISFACTION AND FITNESS FOR A PARTICULAR PURPOSE. APC EXPRESS WARRANTIES WILL NOT BE ENLARGED, DIMINISHED, OR AFFECTED BY AND NO OBLIGATION OR LIABILITY WILL ARISE OUT OF, APC RENDERING OF TECHNICAL OR OTHER ADVICE OR SERVICE IN CONNECTION WITH THE PRODUCTS. THE FOREGOING WARRANTIES AND REMEDIES ARE EXCLUSIVE AND IN LIEU OF ALL OTHER WARRANTIES AND REMEDIES. THE WARRANTIES SET FORTH ABOVE CONSTITUTE APC'S SOLE LIABILITY AND PURCHASER'S EXCLUSIVE REMEDY FOR ANY BREACH OF SUCH WARRANTIES. APC WARRANTIES EXTEND ONLY TO PURCHASER AND ARE NOT EXTENDED TO ANY THIRD PARTIES.

IN NO EVENT SHALL APC, ITS OFFICERS, DIRECTORS, AFFILIATES OR EMPLOYEES BE LIABLE FOR ANY FORM OF INDIRECT, SPECIAL, CONSEQUENTIAL OR PUNITIVE DAMAGES, ARISING OUT OF THE USE, SERVICE OR INSTALLATION, OF THE PRODUCTS, WHETHER SUCH DAMAGES ARISE IN CONTRACT OR TORT, IRRESPECTIVE OF FAULT, NEGLIGENCE OR STRICT LIABILITY OR WHETHER APC HAS BEEN ADVISED IN ADVANCE OF THE POSSIBILITY OF SUCH DAMAGES. SPECIFICALLY, APC IS NOT LIABLE FOR ANY COSTS, SUCH AS LOST PROFITS OR REVENUE, LOSS OF EQUIPMENT, LOSS OF USE OF EQUIPMENT, LOSS OF SOFTWARE, LOSS OF DATA, COSTS OF SUBSTITUENTS, CLAIMS BY THIRD PARTIES, OR OTHERWISE.

NO SALESMAN, EMPLOYEE OR AGENT OF APC IS AUTHORIZED TO ADD TO OR VARY THE TERMS OF THIS WARRANTY. WARRANTY TERMS MAY BE MODIFIED, IF AT ALL, ONLY IN WRITING SIGNED BY AN APC OFFICER AND LEGAL DEPARTMENT.

Warranty claims

Customers with warranty claims issues may access the APC customer support network through the Support page of the APC Web site, www.apc.com/support. Select your country from the country selection pull-down menu at the top of the Web page. Select the Support tab to obtain contact information for customer support in your region.

Guide Specifications

Guide Specifications for the CDU

THIS GUIDE SPECIFICATION IS WRITTEN IN ACCORDANCE WITH THE CONSTRUCTION SPECIFICATIONS INSTITUTE (CSI) MASTERFORMAT. THIS SECTION MUST BE CAREFULLY REVIEWED AND EDITED BY THE ARCHITECT OR THE ENGINEER TO MEET THE REQUIREMENTS OF THE PROJECT. COORDINATE THIS SECTION WITH OTHER SPECIFICATION SECTIONS IN THE PROJECT MANUAL AND WITH THE DRAWINGS. WHERE REFERENCE IS MADE THROUGHOUT THIS SECTION TO "PROVIDE", "INSTALL", "SUBMIT", ETC., IT SHALL MEAN THAT THE CONTRACTOR, SUBCONTRACTOR, OR CONTRACTOR OF LOWER TIER SHALL "PROVIDE", "INSTALL", SUBMIT", ETC., UNLESS OTHERWISE INDICATED.

THIS SECTION IS WRITTEN TO INCLUDE THE 2004 MASTERFORMAT AND THE 1995 MASTERFORMAT VERSIONS. WHERE APPLICABLE, THESE ITEMS ARE BRACKETED AND, IN EACH CASE, UNLESS OTHERWISE INDICATED, THE FIRST CHOICE APPLIES TO THE 2004 MASTERFORMAT AND THE SECOND CHOICE APPLIES TO THE 1995 MASTERFORMAT.

PART 1 — GENERAL

1.1 SUMMARY

- A. These specifications describe requirements for a system designed for cooling distribution to modular InRow CW air conditioners. The system shall be designed to distribute and balance the chilled water / glycol using flexible jointless piping to the air conditioners. The manufacturer shall design and furnish all the piping and fittings required for cooling distribution from the distribution unit to the InRow CW units.

1.2 DESIGN REQUIREMENTS

- A. The cooling distribution unit, manufactured by APC by Schneider Electric, shall include a supply and return distribution manifold. Each manifold should include 12 pipe branches with shut-off and balancing valves. The unit shall be as described in the following specification as manufactured by APC by Schneider Electric.
 - 1. Model number:
 - 2. Total number of InRow CW units:
 - 3. Flow per circuit: (gpm)
 - 4. Water pressure drop through the CDU:
- B. The unit shall be factory-assembled with isolation and balancing valves and shall be designed to be used with jointless flexible piping.

1.3 SUBMITTALS

- A. Submittals shall be provided with the proposal and shall include: overall dimensions of the unit, total of circuits used, maximum chilled water/glycol flow per circuit, calculated run of flexible piping per circuit, and piping connection drawings at the CDU and at the InRow CW.

1.4 QUALITY ASSURANCE

- A. The unit shall be factory tested prior to shipment. Testing shall include complete pressure and leak testing to ensure system integrity. The system shall be inspected for quality control before shipment.
- B. The unit shall be UL Listed to UL 1995 and CSA C22.2 No. 236.

1.5 WARRANTY

- A. The system parts shall be provided with a warranty against defects for a period of 12 months from date of shipment from the factory.

PART 2 — PRODUCTS

2.1 STANDARD COMPONENTS

A. Cabinet Construction

1. The frame shall be 16 gauge formed steel and bolted together.
2. The front and back exterior panels shall be 18 gauge steel and the side exterior panels shall be 20 gauge steel.
3. All exterior panels and corner posts on the frame shall be powder coated black. The unit shall include front removable panels to allow access for system balancing and service and side removable panels to allow for main piping connections.
4. The front panels shall have provisions to be locked with a key.
5. The unit shall include casters for easy installation and leveling feet at each corner.
6. All piping, including headers and distribution lines, shall be insulated with 1/2 in (12.7 mm) closed cell insulation.

B. Connections

1. The main supply line can be piped from either the top or bottom of the unit. The distribution lines are dependent on the version of the unit: top piped or bottom piped. The dielectric flanges allow the unit to be connected to the building chilled water system using copper or iron piping.

C. Valves

1. Each supply branch shall be 1 in (25.4 mm) I.D. and shall include a balancing and shut-off valve to provide a single point of balancing at the distribution unit.
2. Each return branch shall be 1 in (25.2 mm) I.D. and shall include a ball valve for isolation.
3. A 1/4 in (6.35 mm) male flare port with Schrader valve shall be included in each supply and return branch for pressure test and drain.

D. Drain Pan

1. A drain pan with a 1/4 in (6.35 mm) plastic tube connection shall be included at the bottom of the unit.

E. Flexible Piping

1. Jointless flexible piping shall be used for chilled water/glycol distribution from the CDU to the InRow CW units.
2. The piping shall be crosslinked polyethylene/aluminum/crosslinked polyethylene tubing (PEX-AL-PEX) manufactured by PEX-b method.
3. The temperature and pressure ratings of the piping shall be: 200°F (93.3°C) at 100 psi (689.5 kPa), 180°F (82.2°C) at 125 psi (861.8 kPa), and 73°F (22.8°C) at 200 psi (1378.9 kPa).
4. Piping shall conform with ASTM Standard: ASTM E814, ASTM F1281, and NSF Standard: NSF-PW 14 and 61.
5. Piping length shall not exceed 150 ft (45.72 m) from the CDU to the air conditioner and it shall only include fittings at the CDU and at the InRow CW.
6. Pipe connections to the CDU and InRow CW shall be made with pipe fittings that are crimped at each connection to ensure no leakage in the system.
7. All PEX-AL-PEX piping shall be insulated in the field with 1/2 in (12.7 mm) closed cell insulation.

F. Pipe Clamps

1. Pipe clamps shall be factory provided and field installed at least every 32 in (812.8 mm) when piping is installed overhead to properly secure the PEX-AL-PEX piping to the ceiling. (Refer to local codes for exact spacing requirements.)
2. The clamps shall include a center hole that permits the use of a 3/8 in (9.5 mm) threaded rod for anchoring.

- G. Insulation—Insulation shall be 1.38 in (35.05 mm) in diameter by 1/2 in (12.7 mm) thick closed cell insulation.

PART 3 — EXECUTION

3.1 IMPLEMENTATION

A. Installation

1. Installation of the system shall be in accordance to the Guidelines for Installation by the manufacturer.
2. Installation shall be performed by the manufacturer or supervised by the manufacturer's service representative.
3. Installation of piping and connections from the Cooling Distribution Unit to the InRow CW units shall be performed by the manufacturer or supervised by the manufacturer's service representative.

Note: The minimum clearance for overhead piping is 18 in (457.2 mm) from the top of the CDU to the ceiling. The minimum raised floor height for units configured for bottom piping is 12 in (304.8 mm).

B. Start-up

1. Start-up of the Cooling Distribution Unit shall be performed by the manufacturer.

PART 4 — GUIDELINES FOR INSTALLATION

4.01 GENERAL

- A. The CDU provides reliable and flexible fluid distribution to the InRow CW in medium to large data centers (including high density applications). The unit incorporates flexible and jointless piping to provide you with a scalable fluid distribution system that minimizes the risk of leaks within the data center. The CDU will provide years of trouble-free service, when installed by technically qualified personnel.

4.2 SERVICE ACCESS

- A. The InfraStruXure CDU is designed to be a stand-alone unit. It can be placed against a wall or in any open area that is suitable for use. Both side and front panels may be removed during the installation process. An area of 36 in (915 mm) of clear floor space in front and 24 in (609.5 mm) at each side of the unit is required for installation. For service, an area of 36 in (914 mm) of clear floor space in front of the CDU is required. All required maintenance can be performed from the front of the unit.

4.3 RECEIVING THE UNIT

- A. Your CDU has been completely tested and inspected prior to shipment. To ensure that you have received the unit in excellent condition, perform a careful inspection of the crating and the unit immediately upon receipt. Verify that all parts ordered were received as specified. Report any damage discovered to the freight carrier. If necessary, contact the APC by Schneider Electric field service department for help in repairing or replacing damaged parts. While APC by Schneider Electric is not responsible for damage incurred in transit, we want to make sure that you have no undue delays in your system start-up.

4.4 RIGGING

- A. The unit is manufactured with a formed steel frame for maximum strength and unit integrity. However, as with all electrical and mechanical equipment, you must take care with proper rigging of your unit.
- B. When using a forklift to move the unit, use the shipping skid to protect the bottom of the unit. When using chains, cables or rope to lift the unit, use spreader bars to prevent damage to the finished panels.

Note: Due to the ongoing program dedicated to product improvement, specifications are subject to revisions without notice. APC by Schneider Electric assumes no responsibility, and disclaims all liability for damages resulting from use of this information or for any errors or omissions.

Worldwide Customer Support

Customer support is available at no charge via e-mail or telephone. Contact information is available at www.apc.com/support/contact.

© APC by Schneider Electric. APC and the APC logo are owned by Schneider Electric Industries S.A.S., American Power Conversion Corporation, or their affiliated companies. All other trademarks are property of their respective owners.